



# ASTRA KULTURHAUS

Venue Sheet

ÜBER UNS      Seite 3

FOTOS      Seite 4 - 5

GRUNDRISS      Seite 6

GRUNDRISS  
BÜHNE      Seite 7

LICHTTECHNIK      Seite 8

TONTECHNIK      Seite 9

ANFAHRT /  
KONTAKT      Seite 10

## INHALT

## ÜBER UNS

Seit April 2009 ist das Astra Kulturhaus ein beliebter Treffpunkt der Berliner Konzert- und Partyszene.

Entstanden ist der Club auf dem RAW-Gelände im ehemaligen Kulturhaus der DDR Reichsbahn.

Die Konzerthalle mit Clubcharme kokettiert charmant mit „Ost-Design“, bietet Parkettfußboden, verfügt über mehrere Bars und einen großen Biergarten.

Die gute Verkehrsbindung sowie die zentrale Lage machen das Astra Kulturhaus zum optimalen Platz für ausgelassene Konzerte und Partys.



FOTOS



Foyer Hall + Bar



Main Hall



Außenbereich



Bar

FOTOS



# Grundriss

1. Bar 1
2. Bar 2
3. Zufahrt
4. Main hall / Saal 500m<sup>2</sup>
5. Foyer / Partyfloor 300m<sup>2</sup>
6. Außenfloor 70m<sup>2</sup>
  - Raucherbereich
  - Biergarten
  - Außenbar
7. Parkplatz Nighthliner
8. Backstage 1
9. Backstage 2
10. Load in
11. Bühne 75m<sup>2</sup>
12. Garderobe

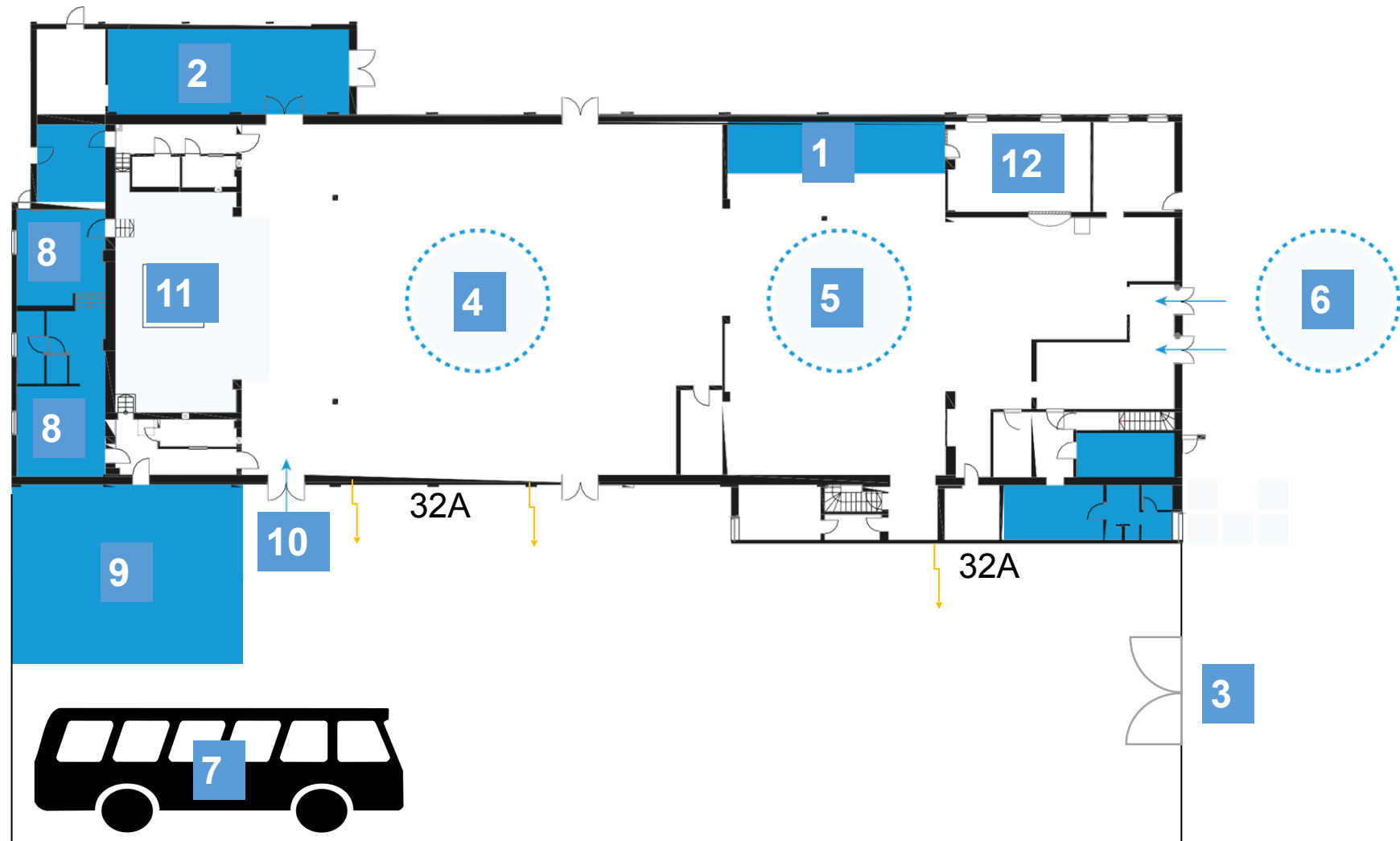

## Grundriss Bühne

1. Stage
2. BS WC 2 / Dusche 2
3. Backstage 2
4. BS Küche
5. WC 3 / Dusche 3
6. Produktionsbüro 2
7. BS WC 1 / Dusche 1
8. Backstage 1
9. zweite Bar

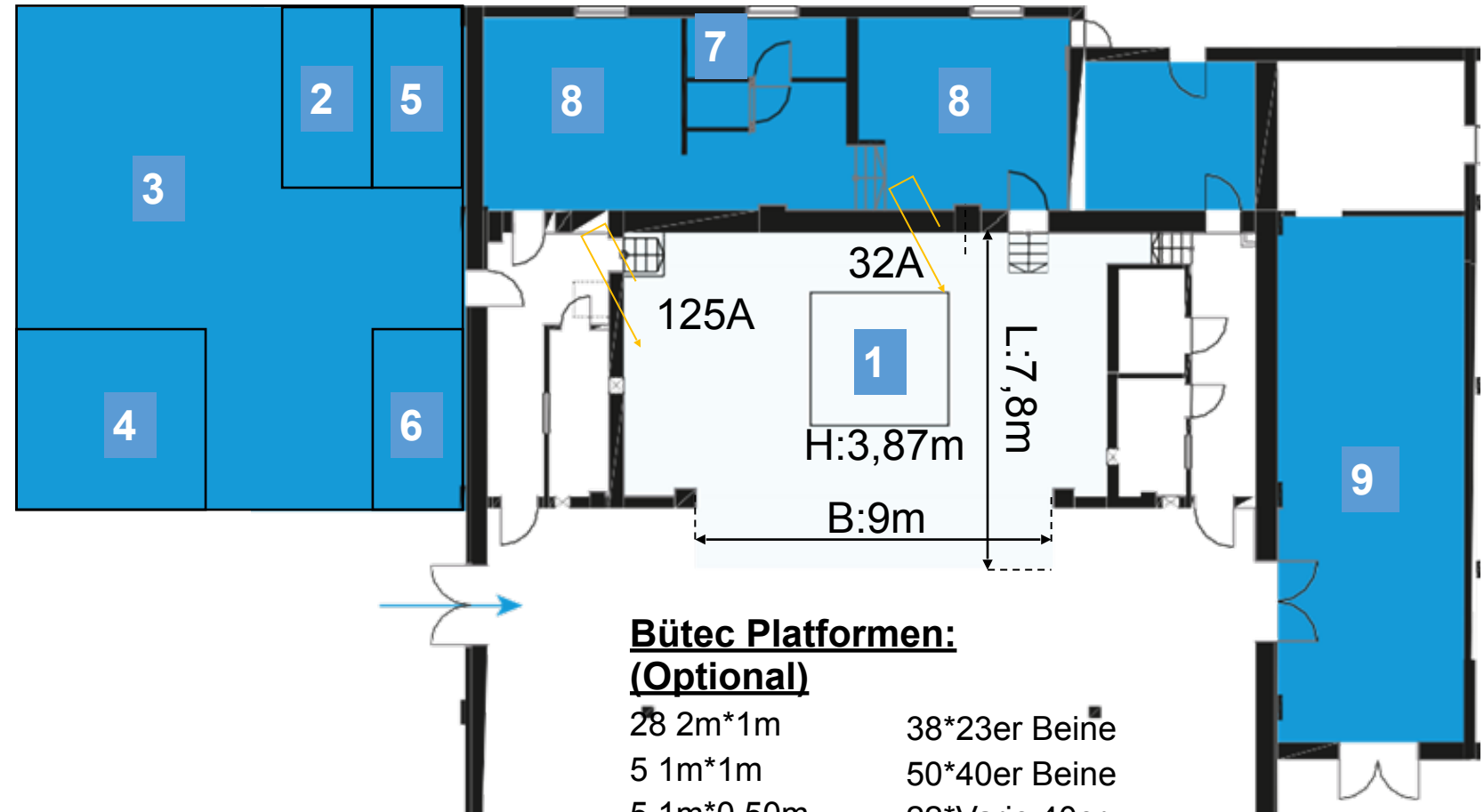

### **Bütec Plattformen:** **(Optional)**

28 2m*1m	38*23er Beine
5 1m*1m	50*40er Beine
5 1m*0,50m	22*Vario 40er
1 2m*0,50m	54*60er Beine
50*20er Beine	20*95er Beine

**Backtruss:** 4 x Arolla Spot Mp  
 4 x Robe LEDBeam 150  
 2 x 6x PAR 64  
 2 x 6x PAR 64 CP 61  
 2 x SGM X5 LED Strobe  
 8 x ACL

**Midtruss:** 4 x Robe LEDBeam 150  
 2 x Arolla Spot Mp  
 2 x 6 PAR 64  
 2 x 2 Lite Blinder  
 1 x ETC SourceFour

**Fronttruss:** 4 x Robe LEDBeam 150  
 3 x 4 Lite-Blinder  
 3 x ETC SourceFour

**Gatwalk:** 4 x 1KW Fresnel  
 4 x ETC SourceFour  
 6 x MAC Aura

**Side:** 2 x 7 x Expolite Tour Led MK2 (R/L)  
 2 x PC Fresnel 650 W (R/L)

**Floorline:** 3 x Atomic 3000 Halogen (optional)  
 6 x Claypaky Actoris ParLED (optional)  
 4 x SGM Q2 (optional)  
 1 x Base Haze

**Beamer:** PANASONIC PT-MZ670  
 HDMI 50m

**Backdrop:** 2 Punkttraverse PROLYTE X30L 8m  
 white wall, Backtruss (4 x 6 m)

**Desk:** Chamsys MagicQ 500M + wing  
 grandMA2 onPC + wing incl. Thinkcentre









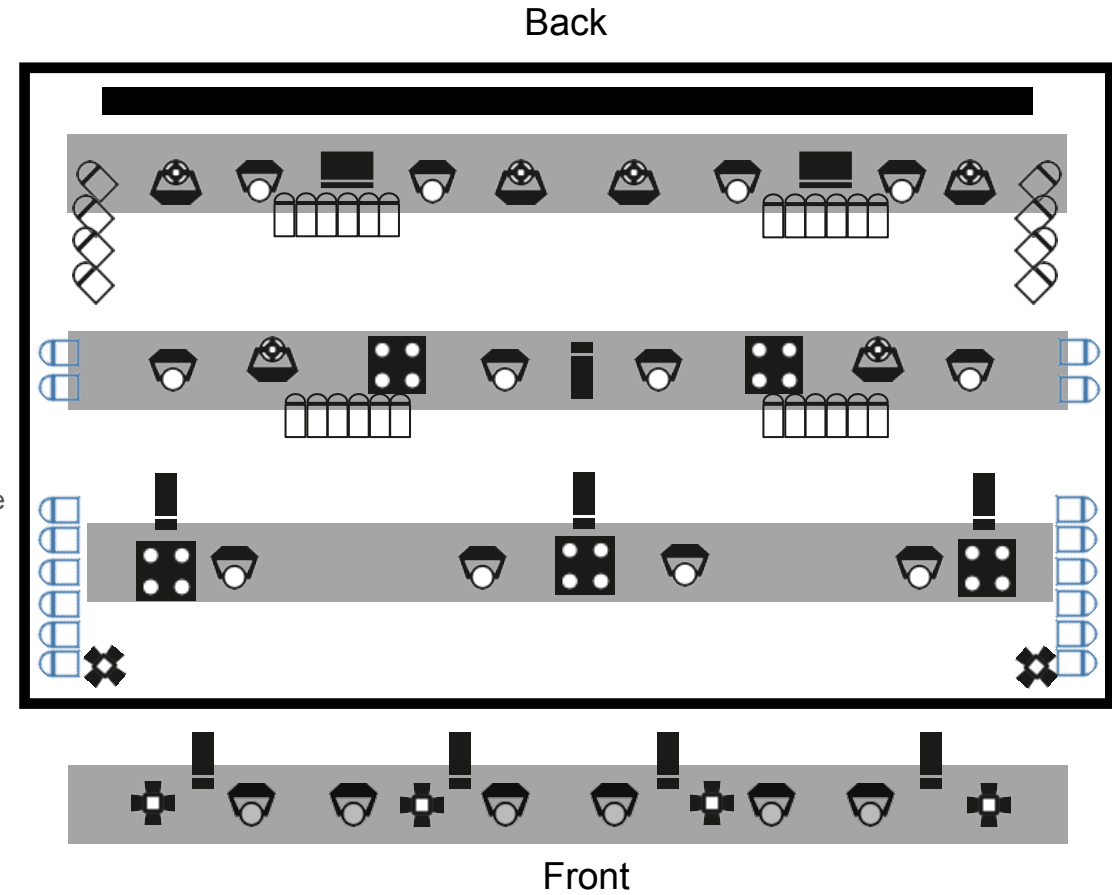

**DMX:** Line I: MovingLights Stage  
 Line II: Static LED + Halogen  
 Line V: Audience Light

**CAT:** 1 x CAT 7 100m  
 1 x CAT 7 50m

**Power:** 1 x 32 A CEE free  
 1 x 125 A CEE free  
 (PSU to 2\*63 A CEE inhouse optional)

**Stage Size:** T: 8,25 m  
 B: 9,10 m  
 H: 1,25 m



- Fixture Type:**
-  CLAY PAKY Arolla Spot MP
  -  1 KW
  -  ROBE LEDBeam 150
  -  ETC SourceFour
  -  MARTIN MAC Aura
  -  PAR 64
  -  EXPOLITE Tour LED MK 2
  -  ACL
  -  Blinder
  -  PC Fresnel L/R
  -  SGM X5 Strob

DMX Patch Stage

BACK

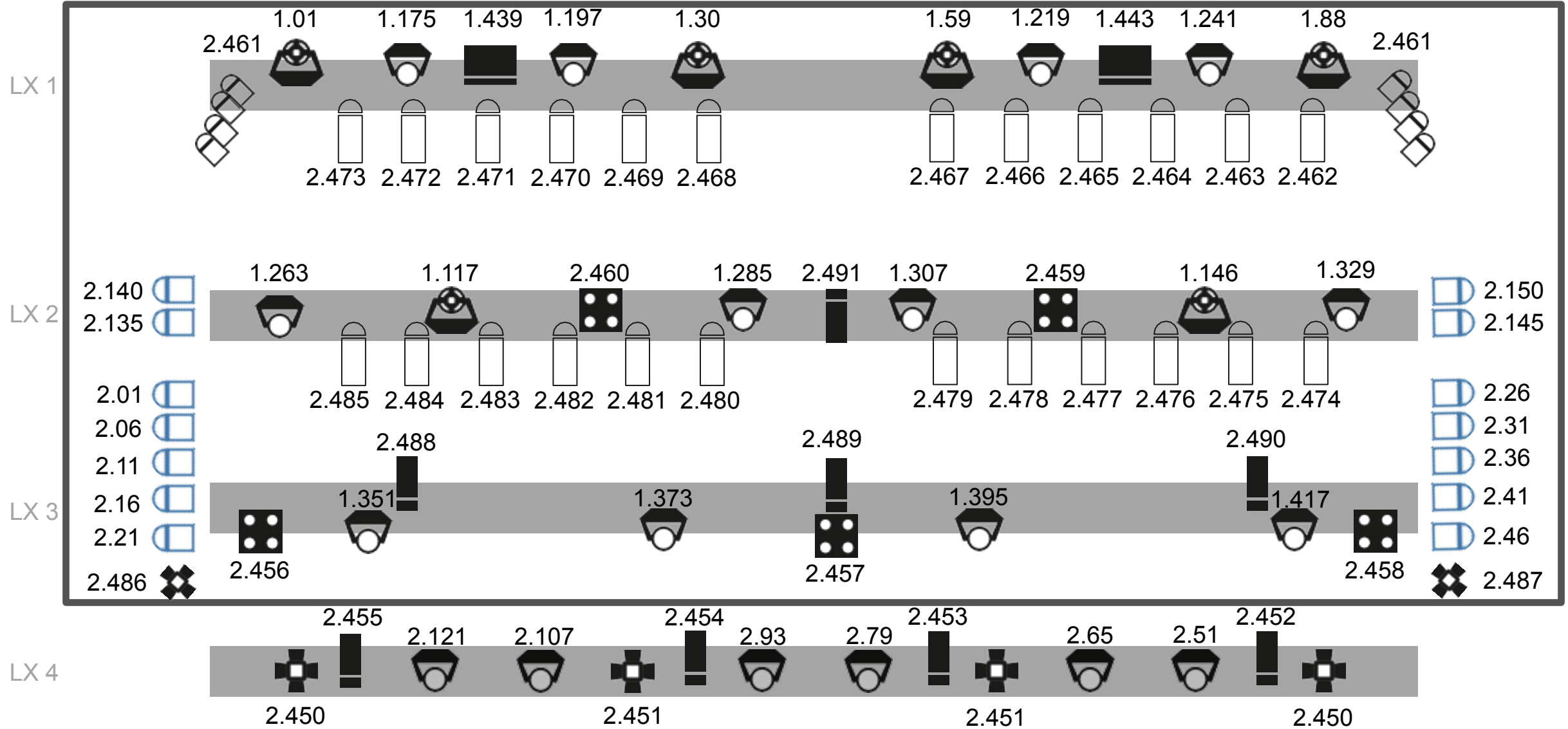

FRONT

# DMX Patch Audience

Stage

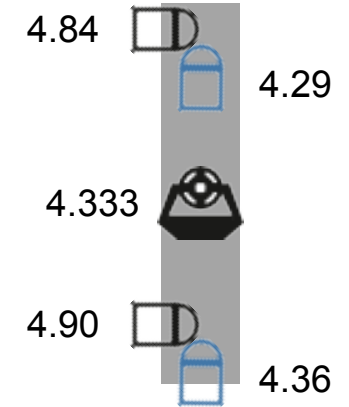
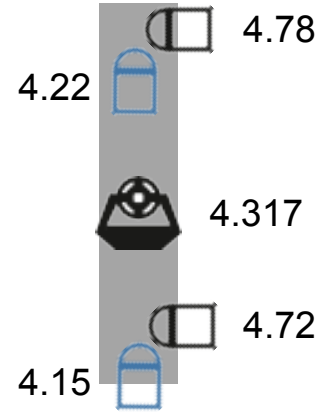

Audience

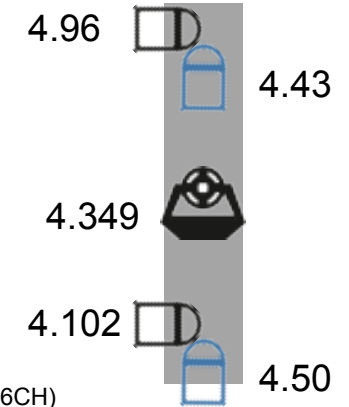
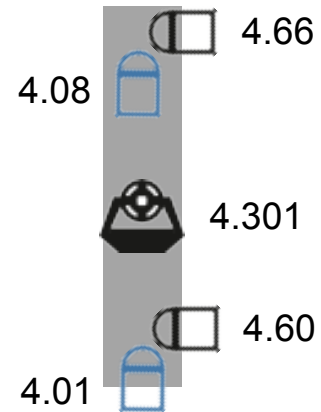

**Legend:**

- GLP Impression fr1 (16CH)
- ADJ Mega Par Prof (7CH)
- ADJ Mega Par Prof (6CH)

Foyer

**MAIN FLOOR**

**FOH:**

**DIGICO Quantum 225** (+WavesDMI)  
MQ Rack (48in / 24out)

**TRAFFIC:**

2 x MADI, dual  
Analogue Lines 12m/12f  
(Übergabe PA :  
Analog LR / LR+Sub / LR+Sub+Center)

**MAIN PA** (Martin Audio):

L+R:  
16 x W8LM ( 2 x 8" / 2 x 1")  
SUB:  
8 x S 218 (4 on each side)  
CENTER:  
1 x W8VDQ ( 4 x 8" / 4 x 1")  
DLY:  
2 x W8VDQ ( 4 x 8" / 4 x 1")

**AMPING:**

L+R: 4 x CREST PRO 8200  
SUB: 4 x CREST PRO 9200  
DLY: 2 x CREST PRO 8200

**CROSSOVER:**

2 x XTA DP448

**MONITORING**

**DIGICO Quantum 225**  
MQ Rack (48in / 24 out)  
Analogue Split

**MONITOR WEDGES:**

9 x MARTIN AUDIO LE 1500  
1 x MARTIN AUDIO F215 (DR Fill)  
1 x MARTIN AUDIO WS18X (Sub)  
2 x MEYER SOUND MSL3 (SF)

**AMPING:**

1 x L' ACOUSTICS LA12X  
4 x CREST C C4000

**STAGE POWER:**

32A CEE on StageLeft

**MICROPHONES & DIs**

1 x BETA 91  
2 x BETA 52  
1 x D 6  
1 x E 901  
1 x E 902  
6 x E 904  
3 x E 604  
3 x E 914  
2 x S M 81  
1 x K S M 137  
2 x S H O T G U N

1 x M D 441  
3 x M D 421  
4 x E 606  
3 x E 906  
8 x S M 57  
8 x S M 58  
8 x E 945  
6 x E 935

**DIs**

6 x BSS active  
11 x LD active  
8 x PALMER active  
1 x RADIAL PRO2 stereo  
3 x PALMER PAN04 stereo  
5 x PALMER PAN01

**FOYER FLOOR PA** (Martin Audio):

4 x F 12+ ( 1 X 1" / 1 X 12" )  
2 x S 218 ( 2 X 18" )

**AMPING:**

MARTIN AUDIO MA 4.2  
CREST C2800

2 WAY ACTIVE 6,5 KW

**PLAYER & MIXER:**

2 x DJM 900 NXS2  
2 x CDJ 2000 NXS2

**TURNTABLE SYSTEM:**

2 x ORTOFON CONCORD CLUB  
2 x ORTOFON DIGITAL

## Anfahrt

### Adresse:

Astra Kulturhaus Berlin

Revaler Str. 99

10245 Berlin

[Google Maps](#)

### Kontakt:

Telefon: +49 30 200 567 67

[info@astra-berlin.de](mailto:info@astra-berlin.de)

### Parken & Load In:

Parkplatz ab 10 Uhr verfügbar

Stromanschlüsse und Load In an der außenseite des Clubs vorhanden.

© 2026 ASTRA KULTURHAUS BERLIN

